

Lifter

Step-by-step assembly instructions

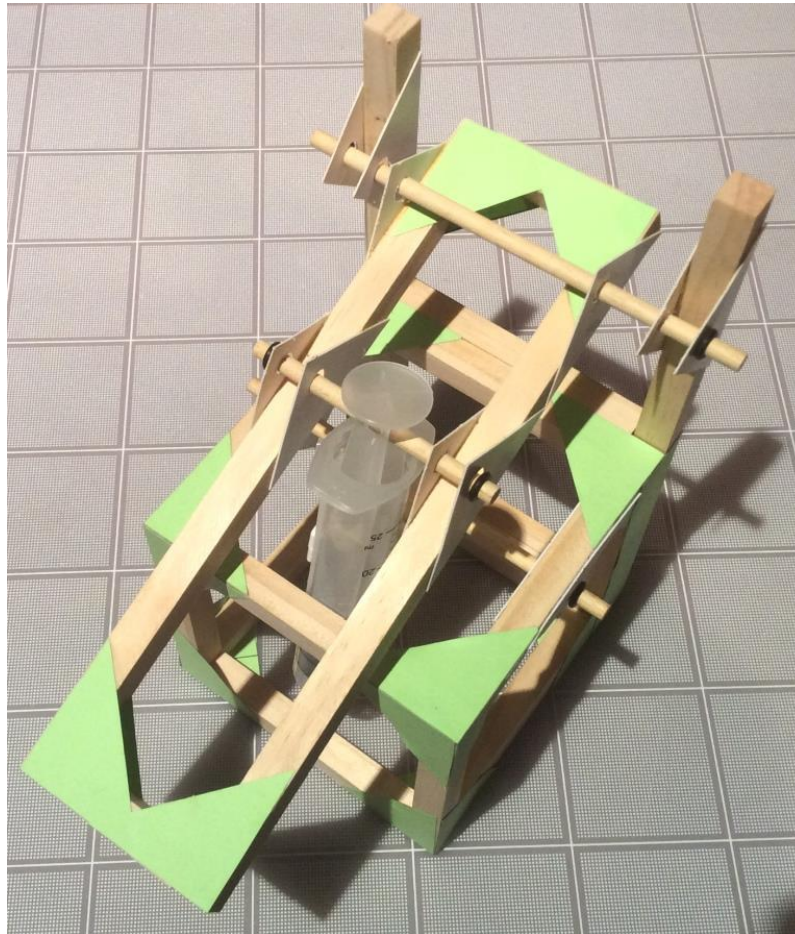

Contents of the Lifter Kit

Wooden pieces ($\frac{3}{8}$ " cross-section):

8 X $3\frac{5}{8}$ " - 92mm; 6 X $3\frac{1}{4}$ " - 83mm ; 4 X 8" - 203mm; 2 X $1\frac{1}{2}$ " - 38mm ; 3 X 1" - 25mm

Green corner gussets: 2 cards

Syringes, 20cc: 2 (1 has a hole in the plunger)

Plastic Tubing: 1 length

Wooden dowel, $\frac{3}{16}$ " - 5mm diam.:

2 X 5" - 127mm; 1 X 3" - 76mm

Axle Holders: 16

Syringe Holder: 1

Mini-washers: 8

Stirring Sticks: 2

Plus a small piece of sandpaper

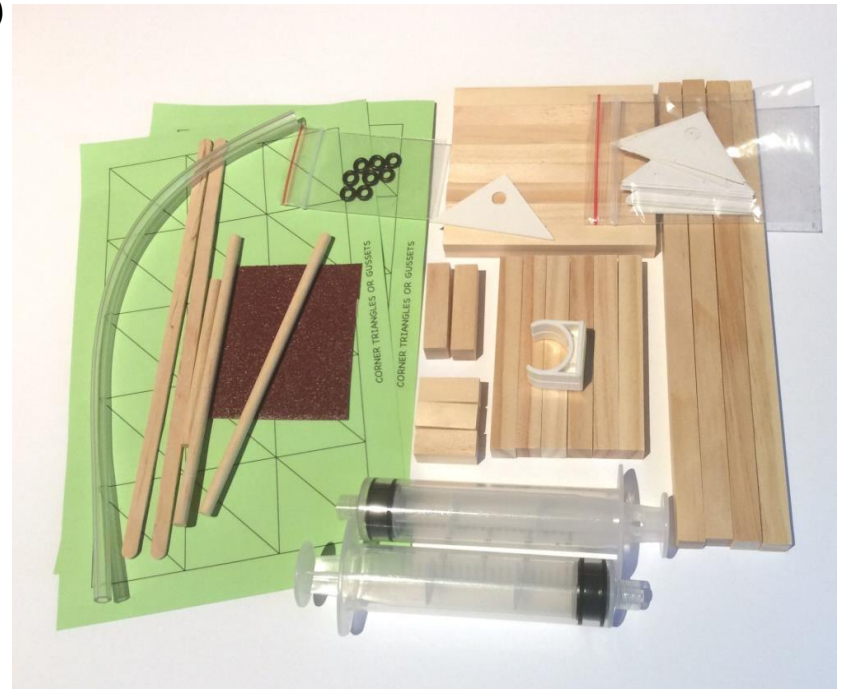

First, make a 4" – 102mm cube

You will need 8 X $3\frac{5}{8}$ " - 92mm pieces and 4 X $3\frac{1}{4}$ " - 83mm pieces.

First make two squares using 4 X $3\frac{5}{8}$ " - 92mm pieces for each.

These images show the steps involved in making the cube.

Note how the pieces are set out. See next slide.

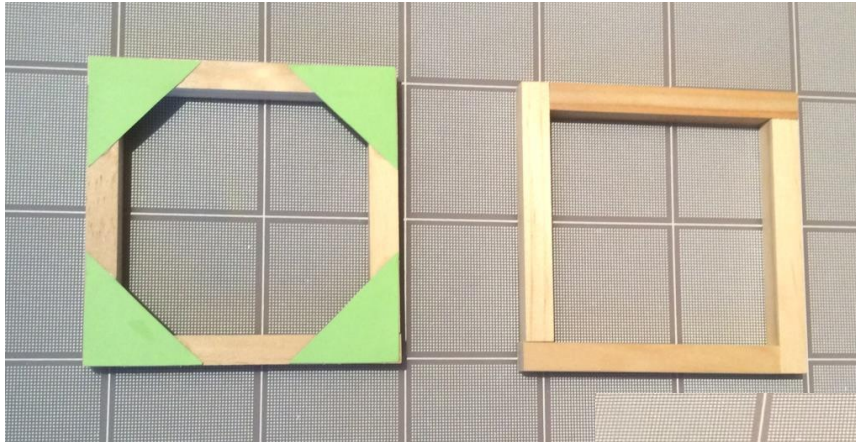

Gluing techniques:

Use sparing amounts of glue.

Use craft stick to spread a thin layer of glue at all joints.

WORKING IN GROUPS
OF 3 OR 4? One/Two
person(s) can move to
page 12 and construct the
small platform and the arm

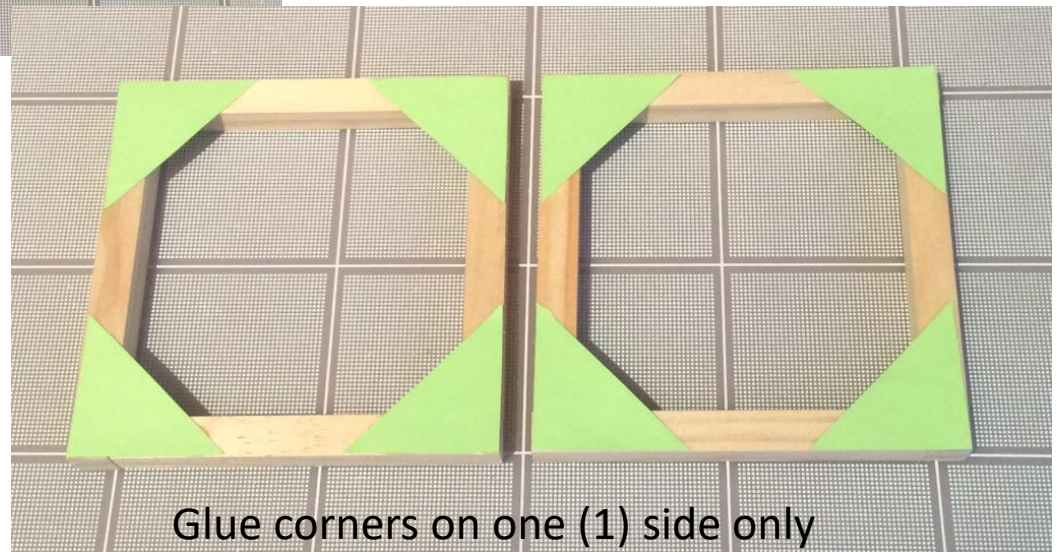

Glue corners on one (1) side only

Just in case you need help making the cube

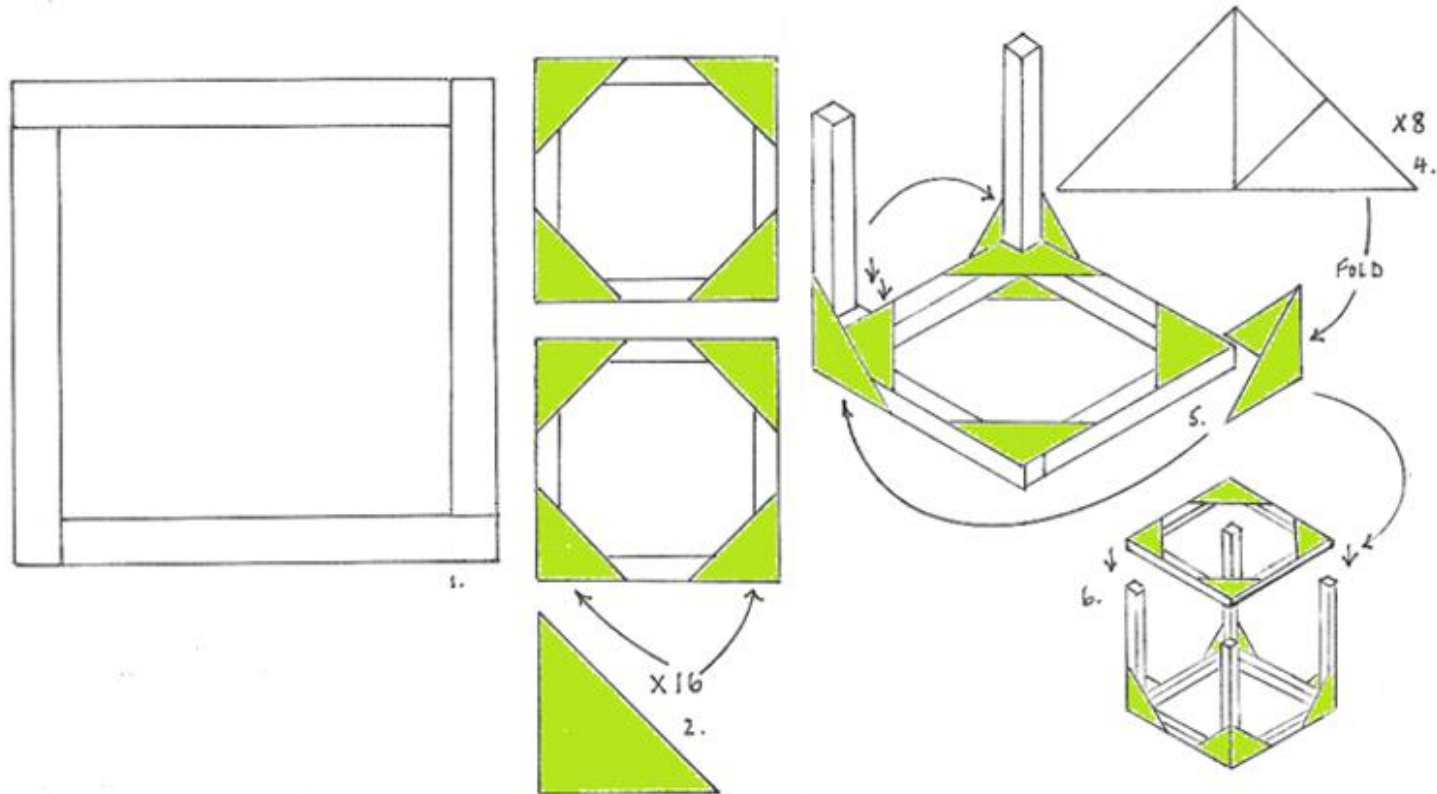

Add 4 X 3¼” – 83mm pieces as uprights.
Notice how a “double-sized” green triangle is used to secure the corners

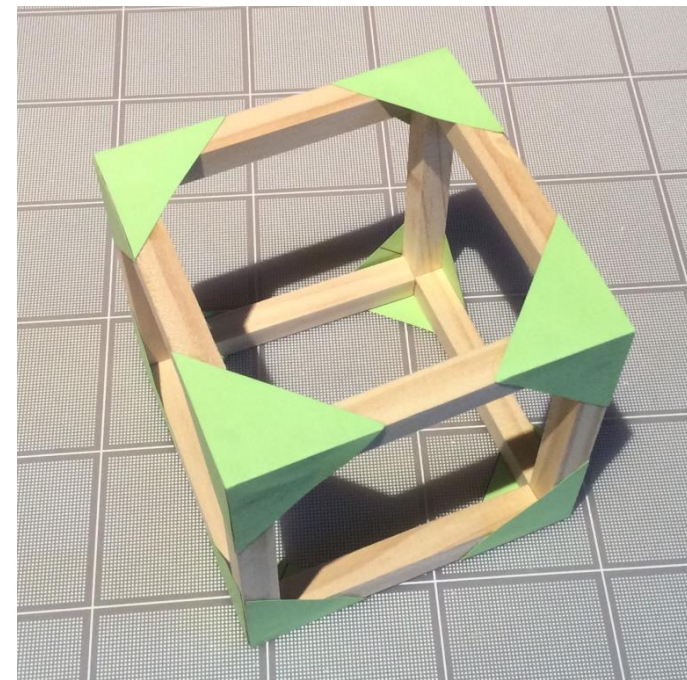
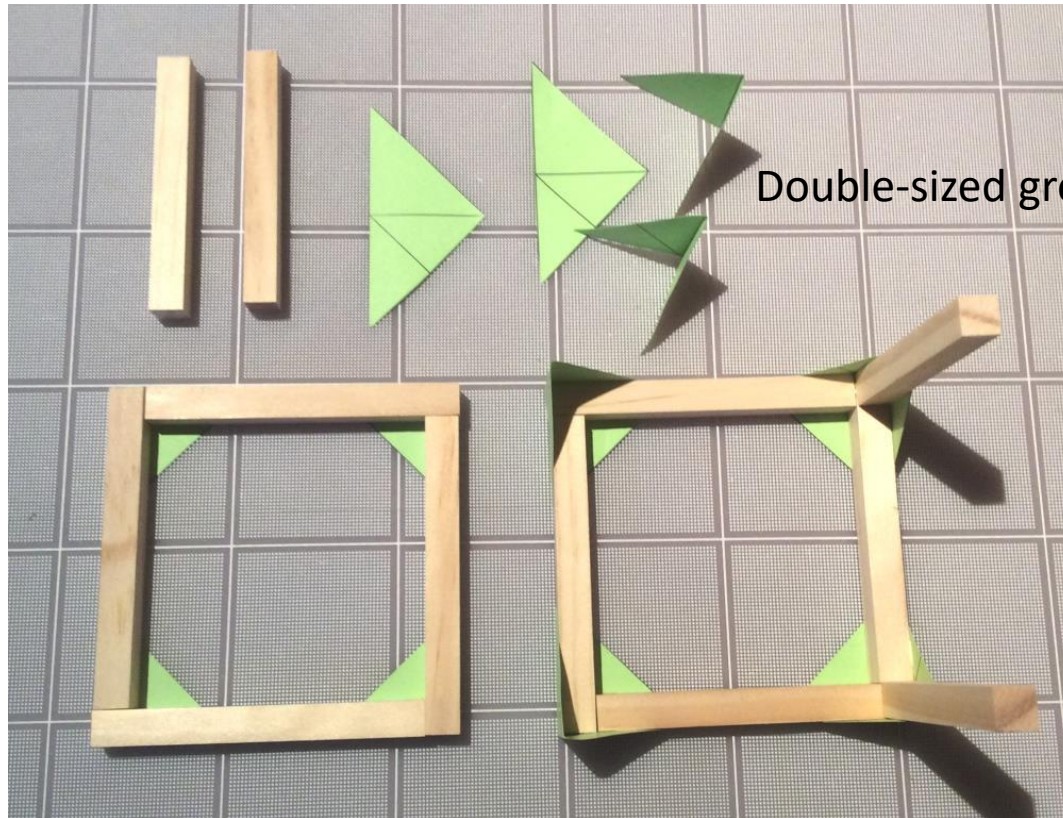

Add to the cube to make the structure for the Lifter.

Glue two 8" - 203mm pieces to one side of the cube. Reinforce by gluing two strips 4" x 3/4" (101mm x 19mm) on the side – cut these from the green card

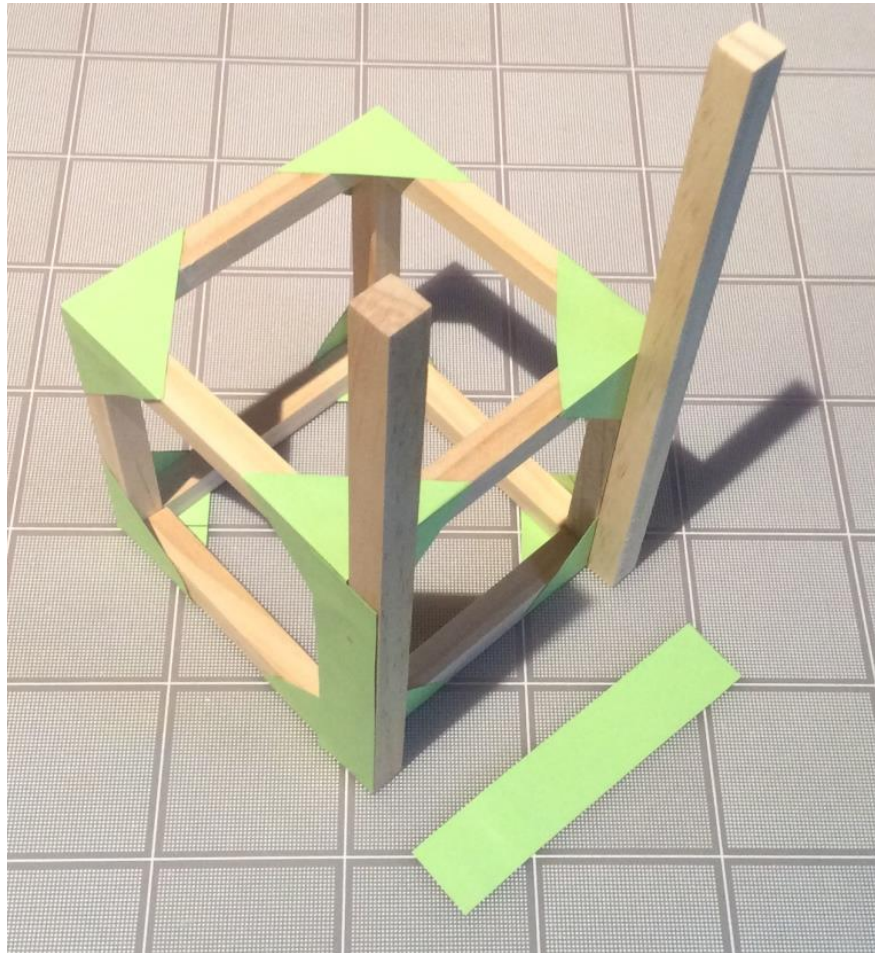

Glue two 3¼" - 83mm pieces between the 8" - 203mm uprights and reinforce with four green gussets or triangles



Glue an axle holder onto the outside of the top of the cube as shown. Mark the center of the axle holder and mark $2\frac{1}{2}$ " - 64mm from the edge furthest from the uprights. Glue the axle holder into position checking it is horizontal and parallel to the $3\frac{1}{4}$ " - 83mm piece you glued in last

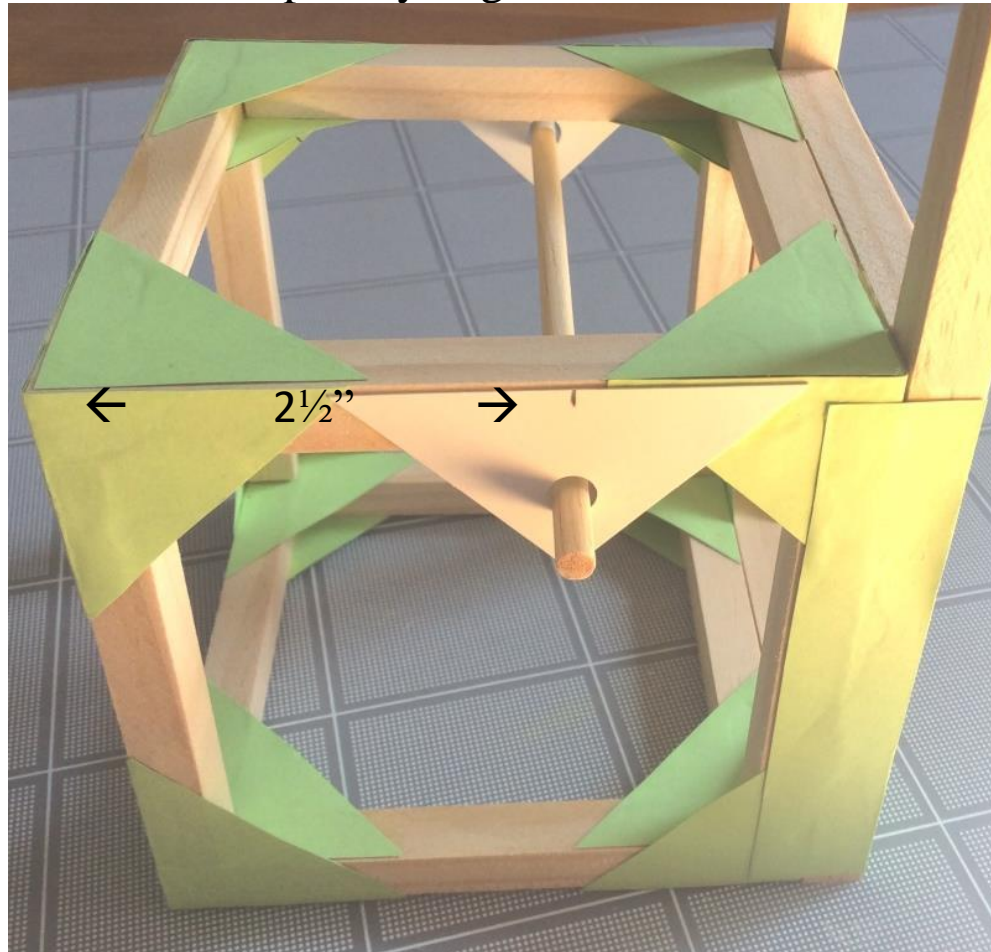

Glue two more axle holders on the inside edges to reinforce. Make sure the holes line up



Glue an axle holder onto the outside of each upright so that the centre of the hole is 1 ½”-38mm from the top of the upright and the hole points towards the cube. Once horizontal and perpendicular to the uprights glue two more axle holders on the inside

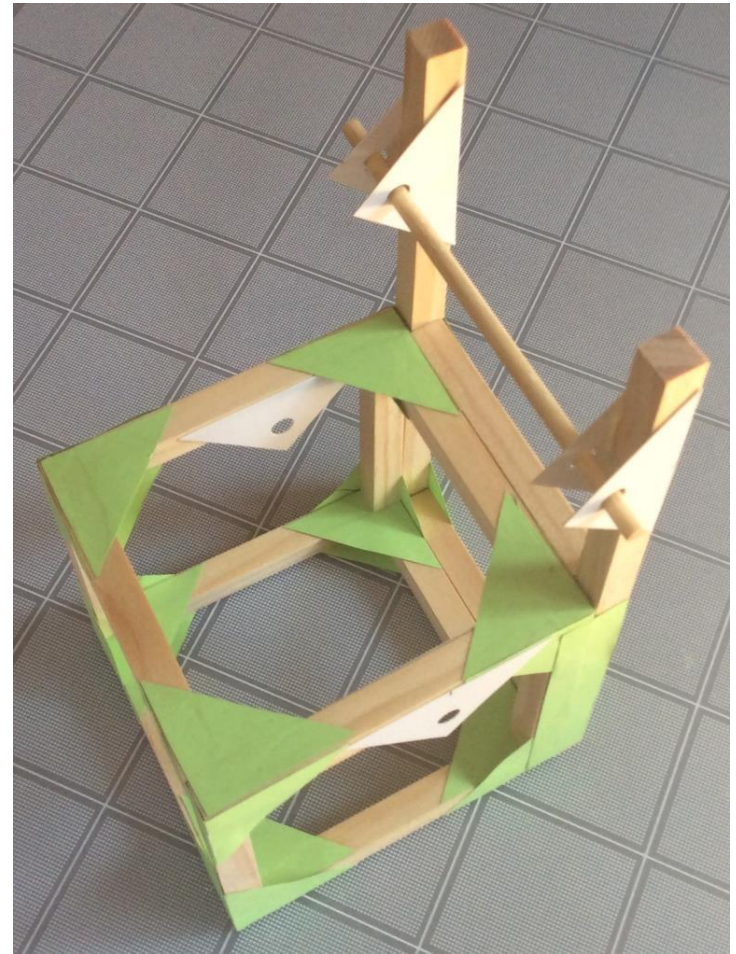

Once everything is dry, test in the structure using a 5" - 127mm axle and ensure smooth rotations. In the meantime, see where the small platform is in the pic below.



Glue together three 1" – 25mm pieces using glue between the pieces. Glue two axle holders to opposite sides and trim. This is the platform that will hold the white syringe holder of the piston-syringe that moves the arm

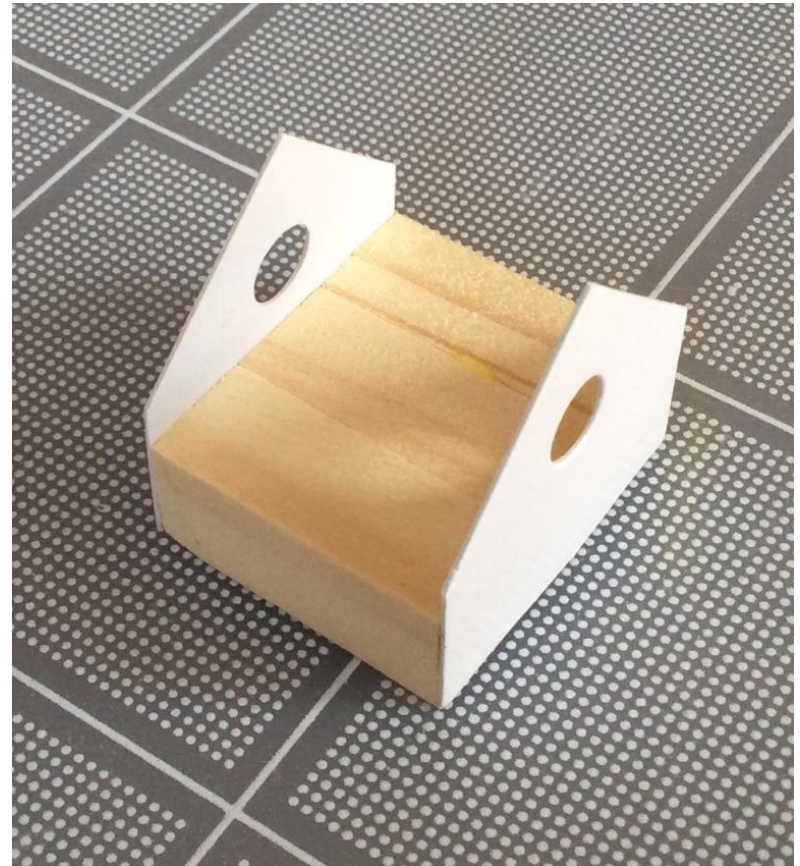
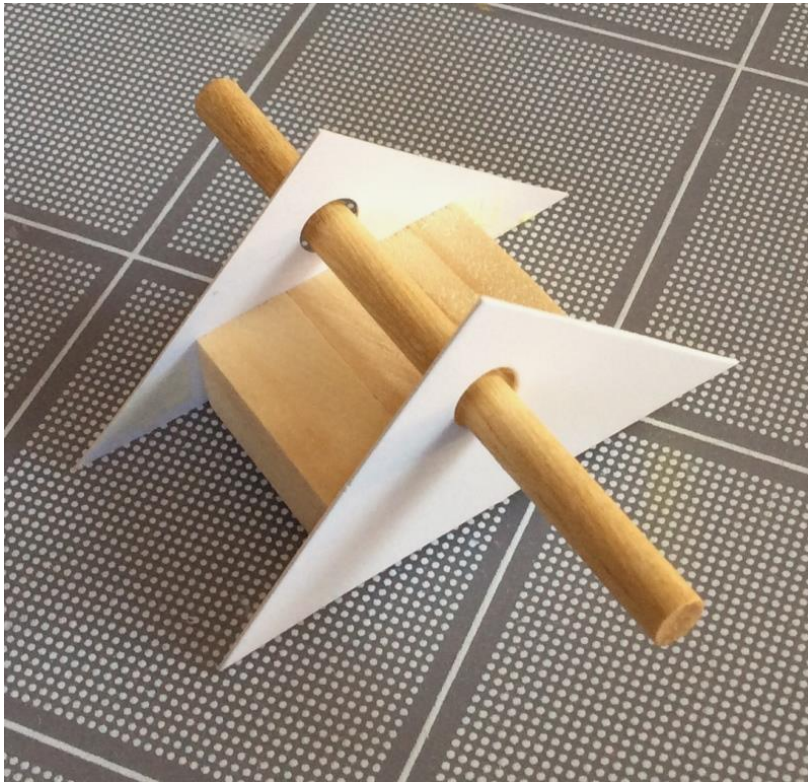

Make the arm by connecting two 8" - 203mm pieces and two 1 ½" - 38mm pieces.
Use 8 corner gussets – four on each side.

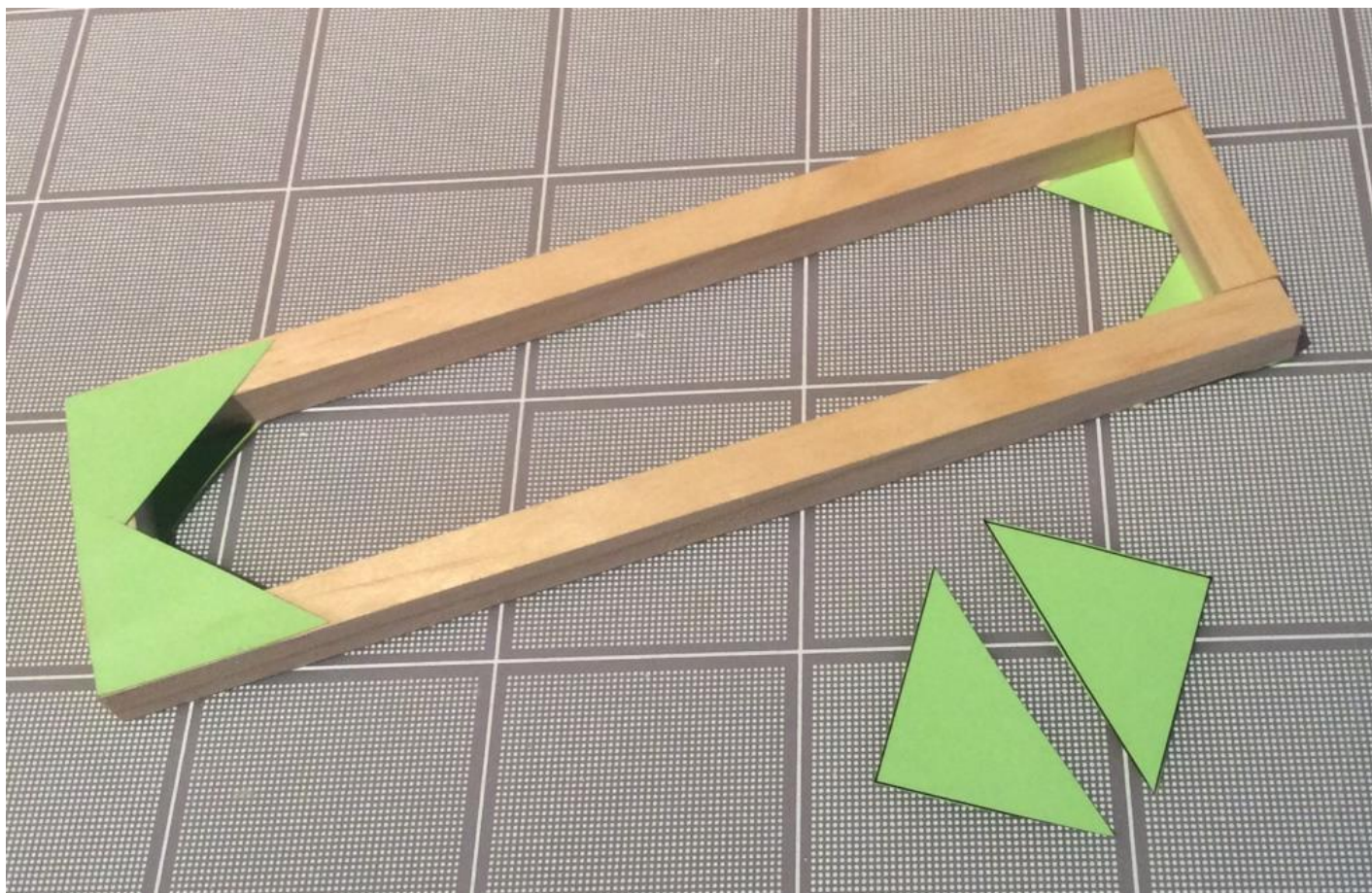

On the frame glue an axle holder in place so that its smallest angle touches the corner of the frame. Use a 5" - 127mm axle to align and glue another axle holder on the outside of the opposite side. Test that the axle sits across the frame parallel to the shortest end

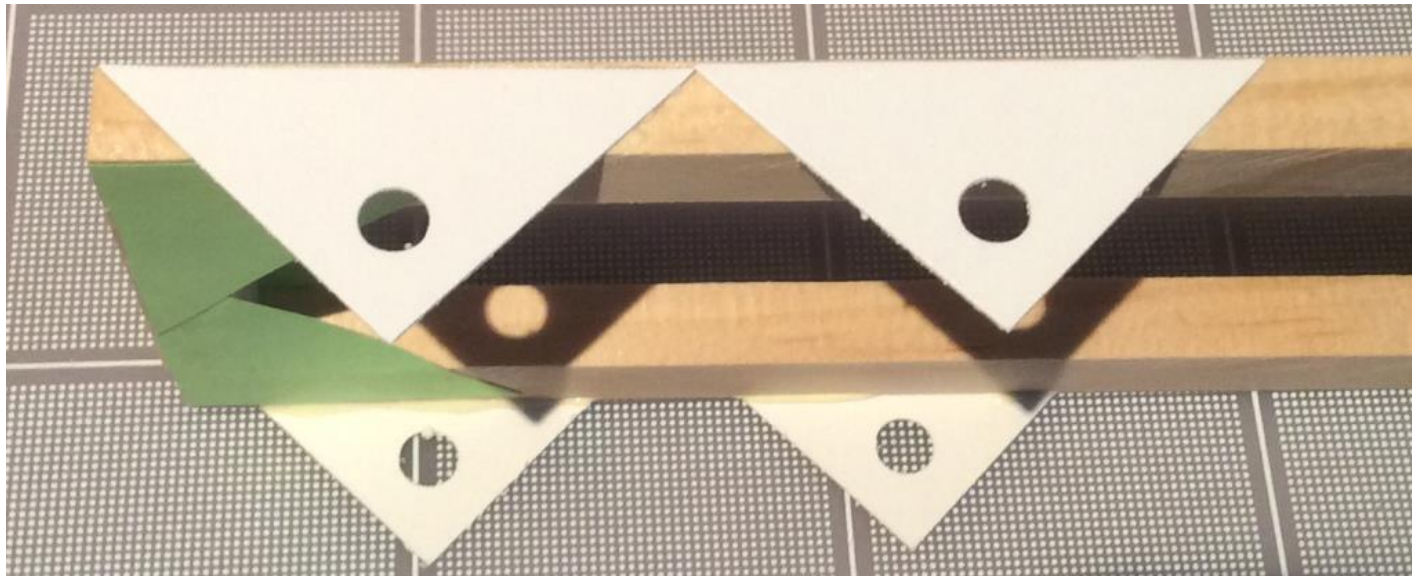

Glue another axle holder in place so that its smallest angle touches the other smallest angle of the first axle holder glued to the frame. In the same way and using the 3" - 76mm axle, align and glue in place another axle holder on the outside of the opposite side. Follow by aligning and gluing in place two more axle holders on the inside of the frame. The four axle holders must allow for a smooth rotation by the 3" - 76mm axle

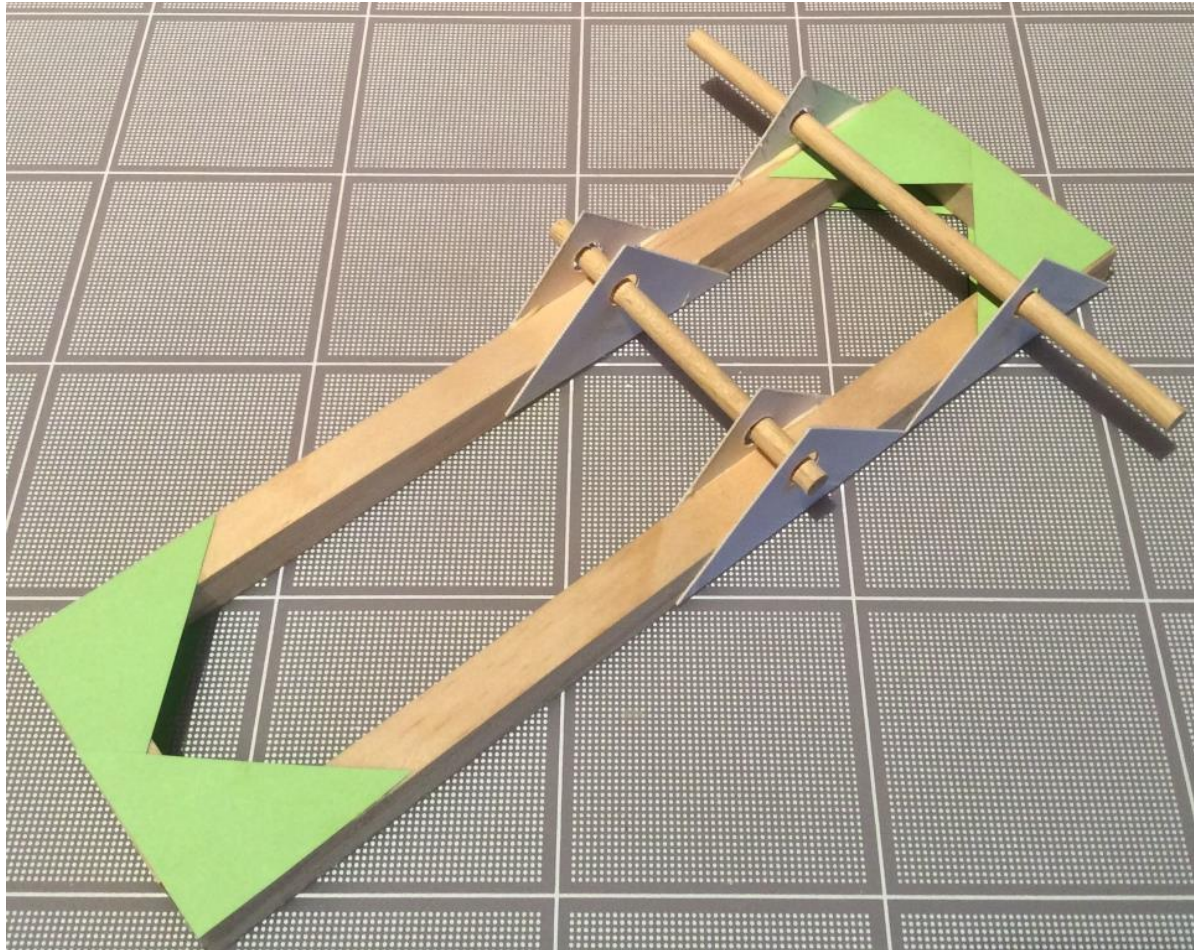

There are a number of steps in assembling the mechanism. The first is to identify the syringe that has a hole drilled in its plunger. The 3" -76mm axle fits through this hole and should turn in it. The axle and plunger fit between the double axle holders on the arm and the protruding, axle is secured using a mini-washer on each end

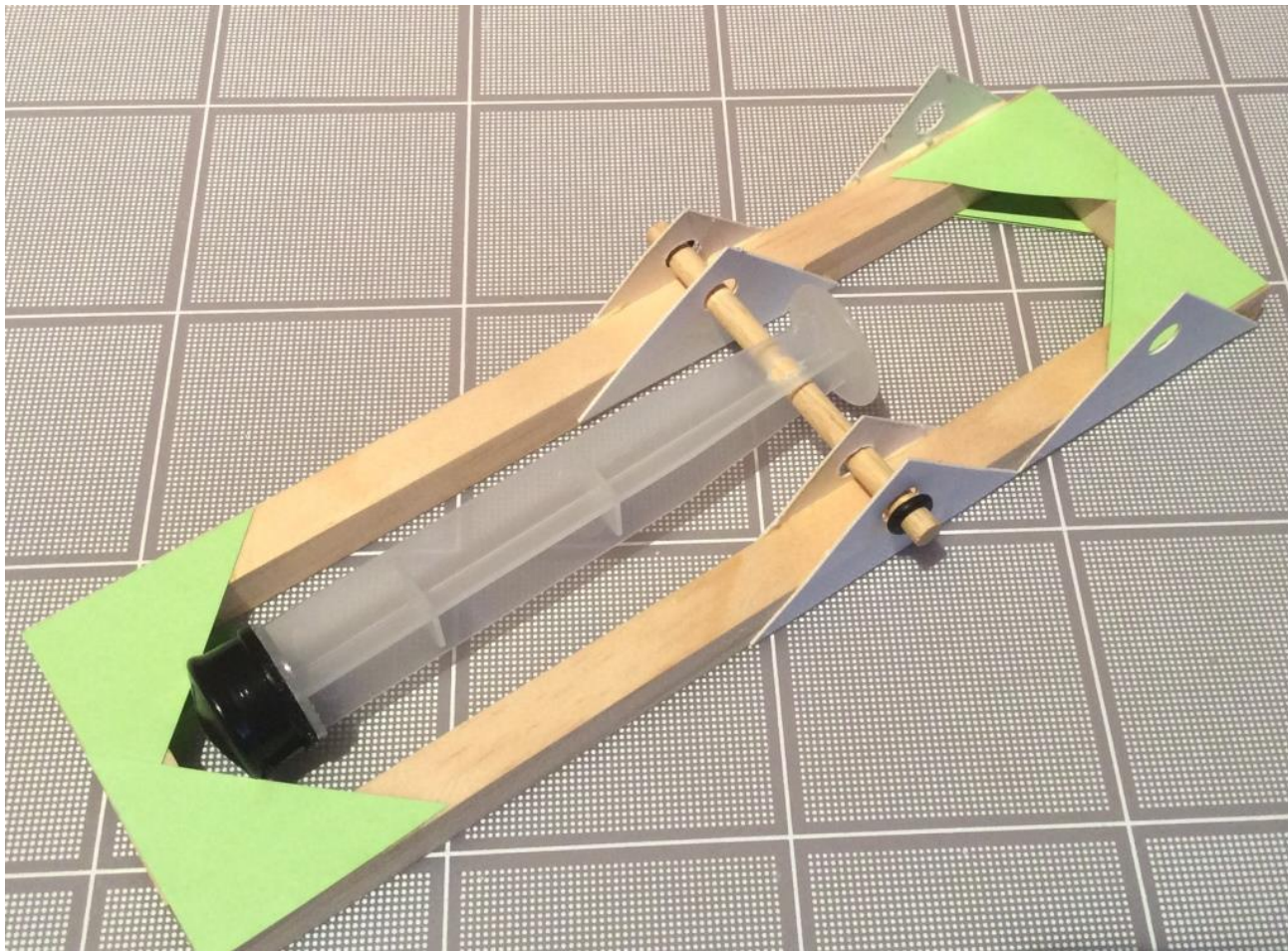

Strip the backing from the white piston syringe holder and press it firmly onto the platform



Place the barrel of the syringe into the clip so that the clip aligns with the 15cc mark or thereabouts. Be careful to orientate the barrel lip as shown



Mount the syringe platform onto the structure so the lip points toward the 8" - 203mm uprights and the barrel is above the axle. Secure with four mini-washers, two securing the syringe platform and two securing the axle ends on the outside of the structure

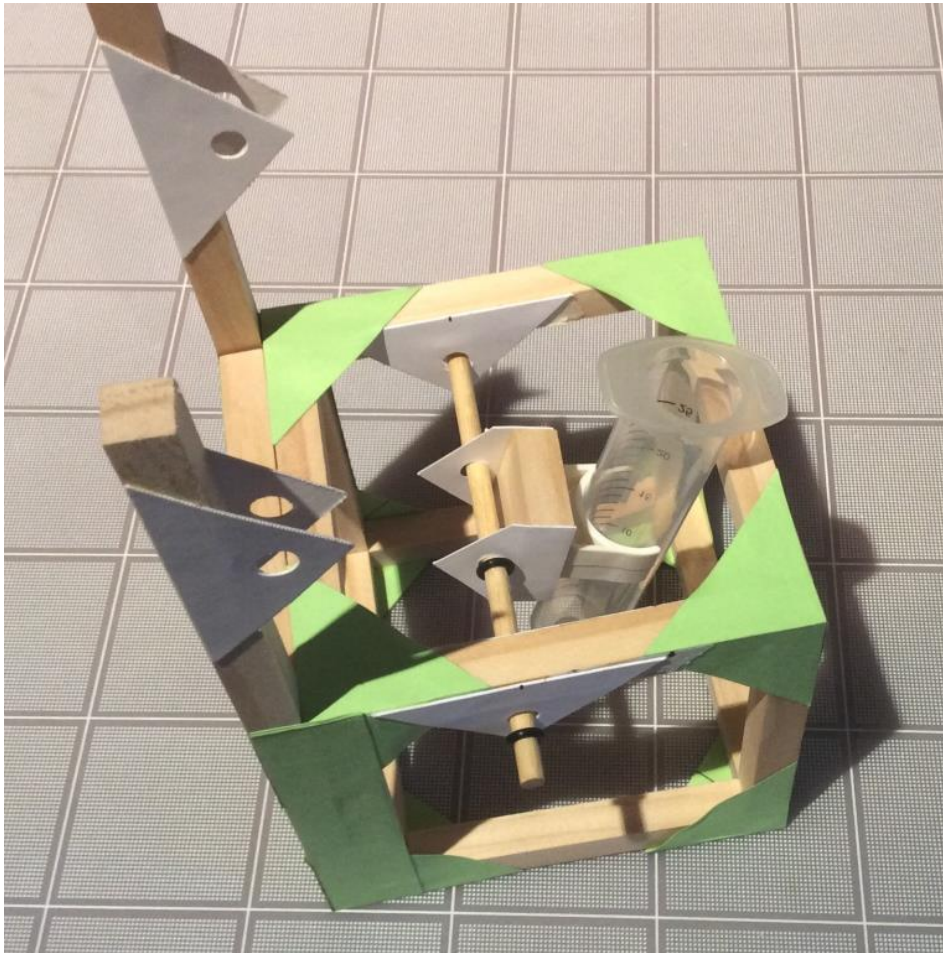

Carefully insert the plunger into the barrel of the syringe until the holes of the white axle holder at its end align with the holes in the axle holders glued to the 8" – 203mm uprights on the structure. Once aligned, carefully insert a 5" – 127mm axle through all six holes. This axle is secured with a mini-washer at each end

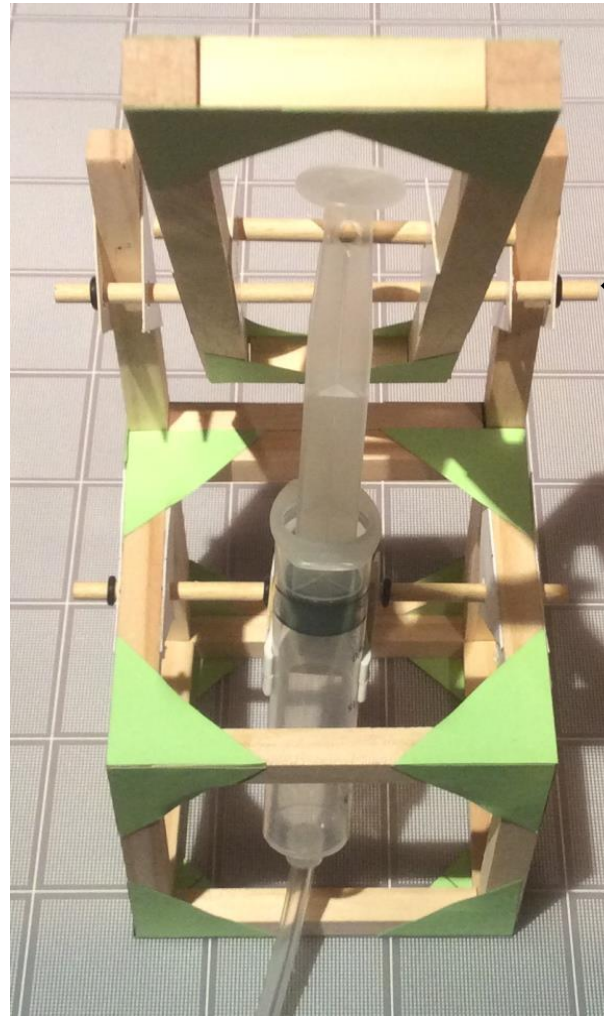

← axle through all six holes

To operate the mechanism attach the length of plastic tubing to the end of the acting syringe that is now housed in the structure. The other syringe should be fully extended before it is connected to the other end of the tubing. Gently push the plunger down. This syringe drives the acting syringe and the arm will move up

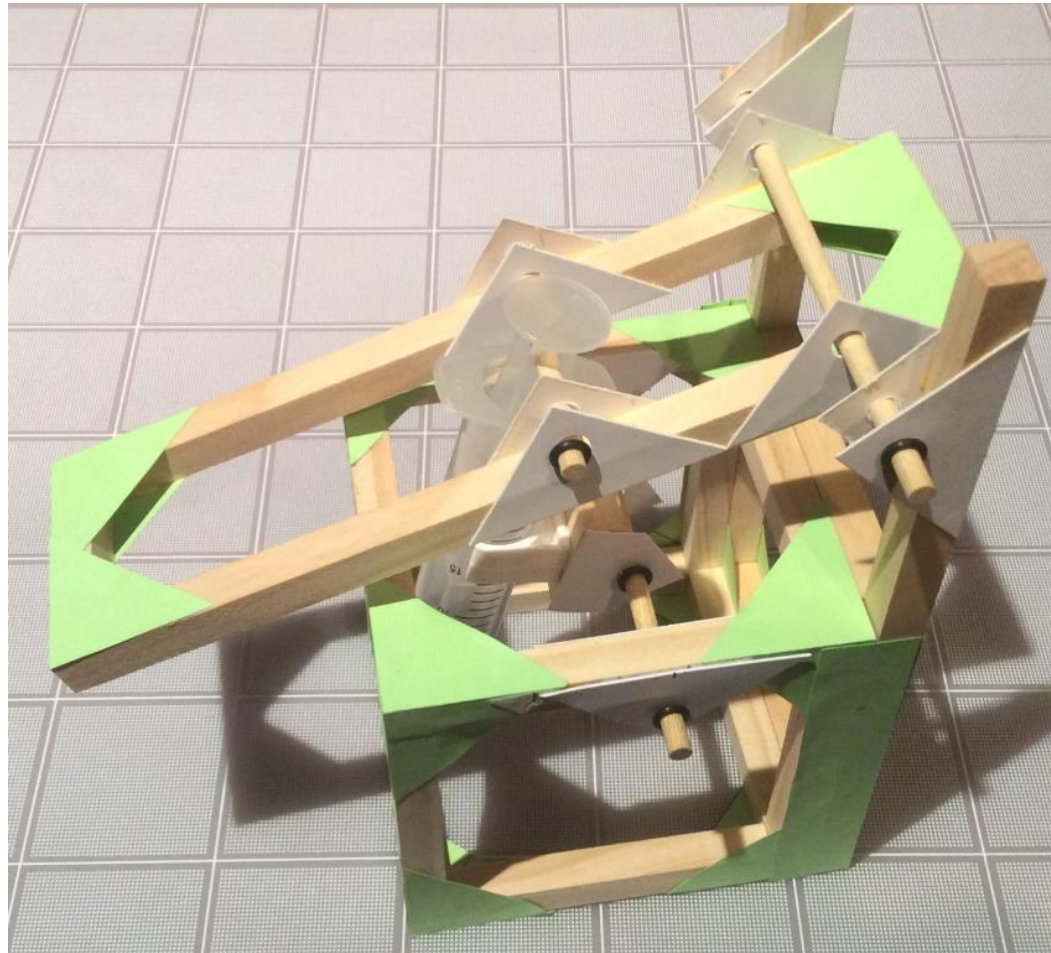

LIFTER - open

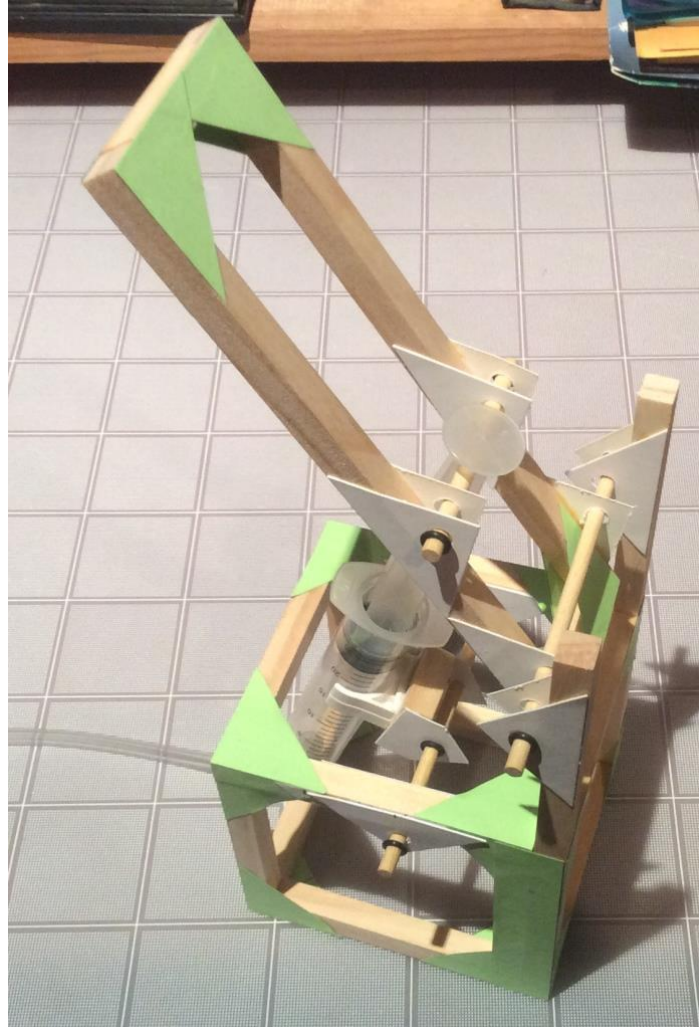

THE NUMBER #1 REASON THE CLIP TEARS FROM ITS BASE

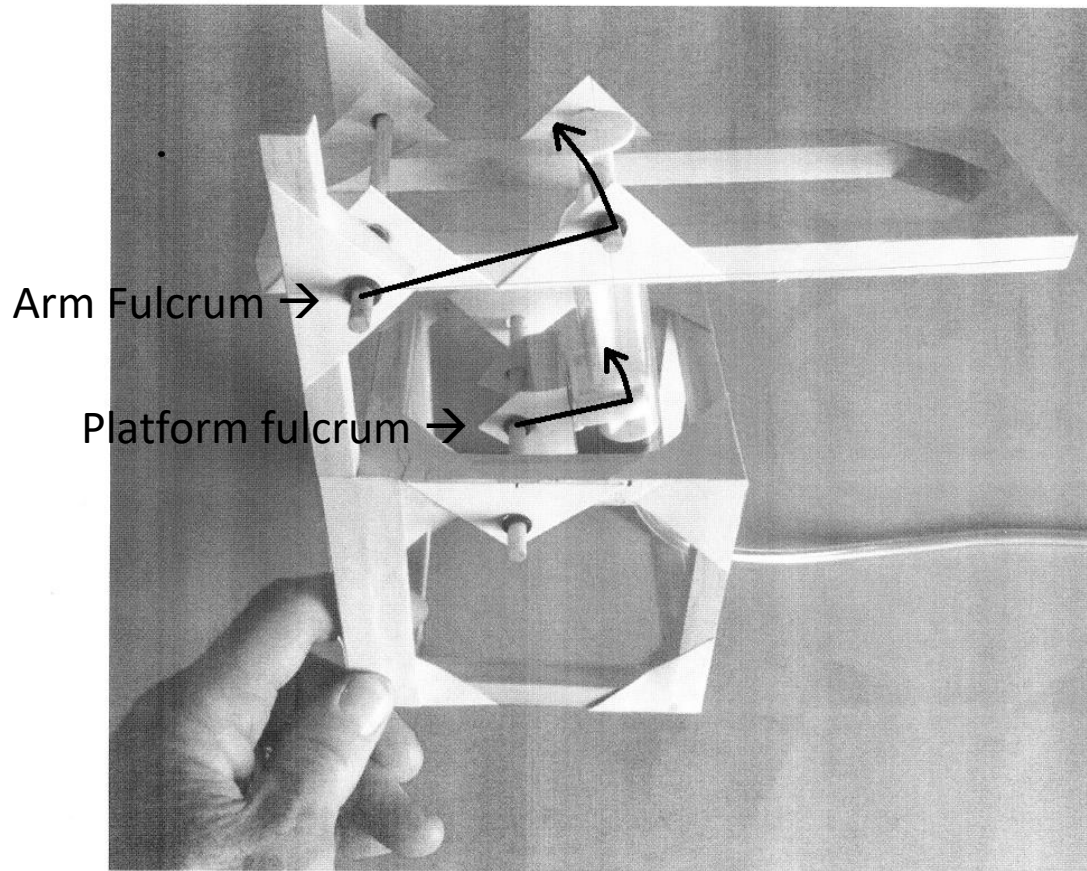

AS THE ARM TURNS SO MUST THE PLATFORM IT IS MOUNTED ON