

ATTACHING PISTON-SYRINGES

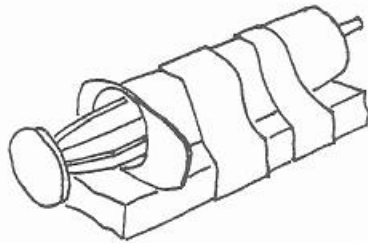
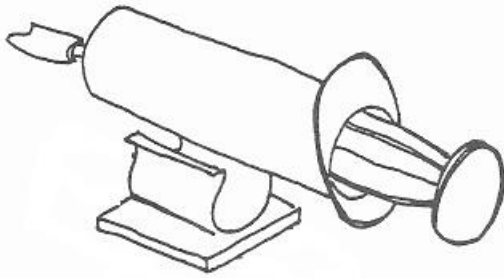

Gray and white clips are provided for attaching piston-syringes. Both have sticky pads on their base. The gray clips accommodate a 20cc syringe and have a larger footprint. The smallest of the white clips is for a 10cc syringe.

It is important to know how to use the clips with an additional cardboard base so that they remain secure.

There are other ways to connect a piston syringe to wood using tape or twisty ties.

Hot glue is ONLY a temporary LAST resort.

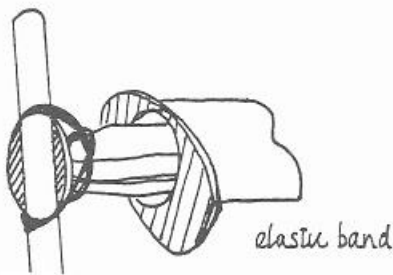

Using an elastic band and a stirrer or popsicle stick is a useful way of lining things up temporarily.

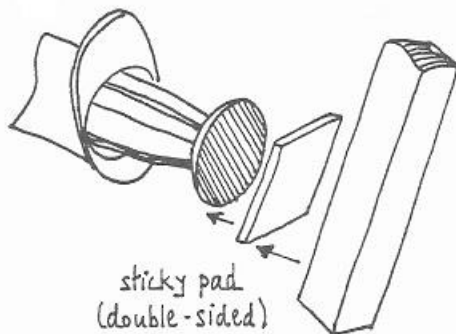

Using a double-sided sticky pad is a better way to join the plastic plunger to wood or, better still wood and cardboard.

Another idea is a hinge made from thicker cardboard (like the box). Fold the cardboard in two and attaching a sticky pad to each half and then, one side to the plunger and the other to the wood.

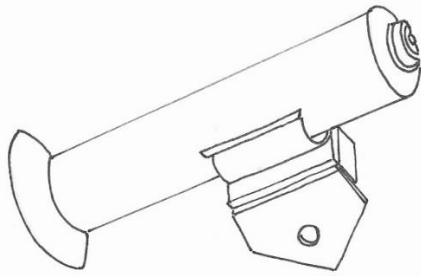

This is the standard method for connecting a piston-syringe to a base so that the piston-syringe can rotate vertically. Three small pieces are joined so that an axle will rotate in the aligned holes. Alternatively white axle holders and 3 small pieces without holes are joined, as shown.

Note that cardboard is used to cover the wooden pieces. It must be allowed to dry before the clip is stick to the platform.

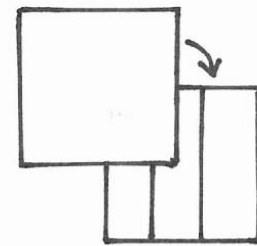
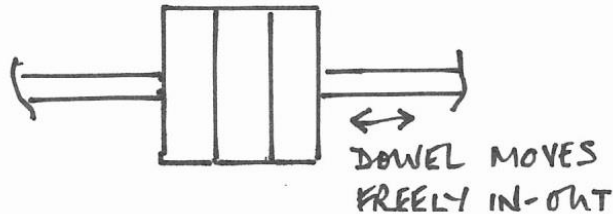
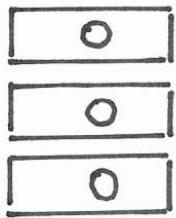

GLUE CARDBOARD
PIECE ONTO PLATFORM

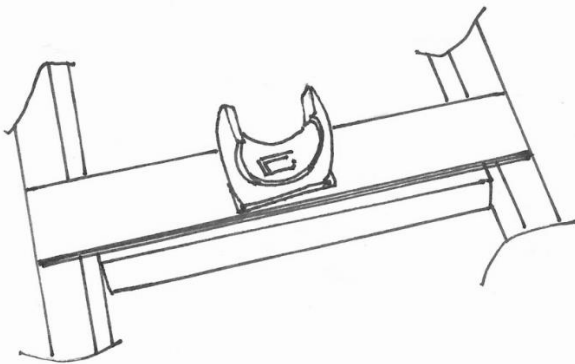

A white clip can be used instead of a gray one. The footprint of the sticky pad beneath the clip is small and therefore cardboard is used to ensure a strong connection.

When linear to linear motion is required, the clip does not have to rotate on a platform. A rectangular strip of cardboard, cut from the green sheets, is glued to the wood. When dry the clip is pressed onto the cardboard once its position is determined. This is important as it is difficult to re-stick the clip if removed.

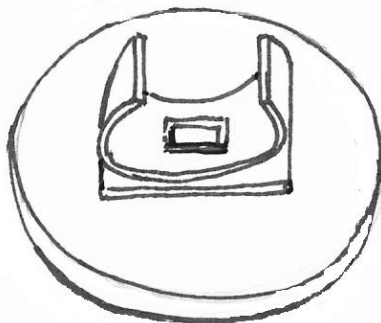

If the piston is to act in a linear to rotary fashion, then it must have a base that rotates. The usual way is to use a wheel with a dowel through its hole to keep it in position, and again, cardboard between the clip and the wheel (as in the Rotating Base kit)

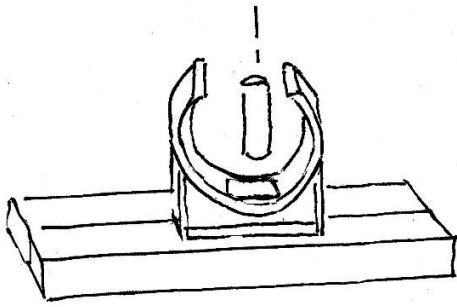

A good idea! A hole is drilled into a base formed by two strips and through the base of a white clip. A small dowel, sanded to size, is used to fix the clip to the base

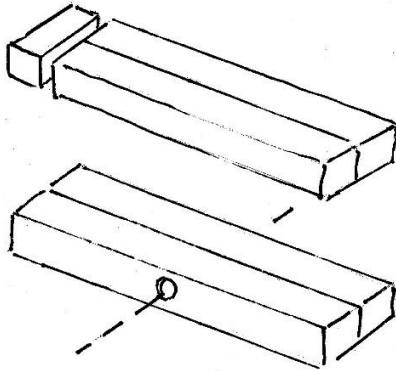

Another great idea! A way is required to stop the barrel of the piston-syringe moving forward. The base has two layers, the top layer is formed by three pieces as shown.

The base can either rotate through a hole drilled through the base, or by using white axle holders glued to the base

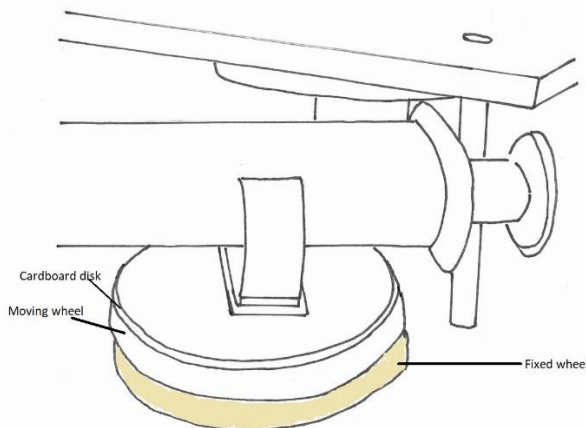
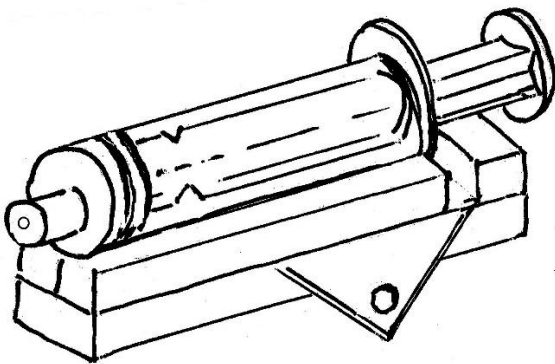

A diagram illustrating the arrangement for connecting a piston-syringe, with a hole in its plunger, to a square platform. The lower wheel is fixed. The clip is firmly pressed onto a cardboard surface.